



## Sweet Dream

Silgan Plastics is a leader in the design and manufacture of plastic bottles, jars, tubes, caps and fitments for the food, health care, personal care and household markets. Silgan Plastics is an operating company of Silgan Holdings, a leading manufacturer of consumer goods packaging products with annual net sales of \$3.1 billion in 2010.

When Cargill made plans to introduce a spoonable version of its Truvia™ zero-calorie natural sweetener, it asked the Silgan Plastics' Creative Design Services group to develop an innovative container. Cargill was looking for a 9.8 ounce rigid, recyclable container that would allow consumers to conveniently dip, spoon or sprinkle Truvia in quantities of their choosing. The package needed to fit the average retail shelf and be sufficiently distinctive and attractive so that consumers would want to display it on their table or countertop.



“

FDM models play a critical role in our design process by allowing customers to evaluate a 3-Dimensional model to take the guesswork out of the design process.”

Stephen Kocis  
Creative Design Services Manager, Silgan Plastics

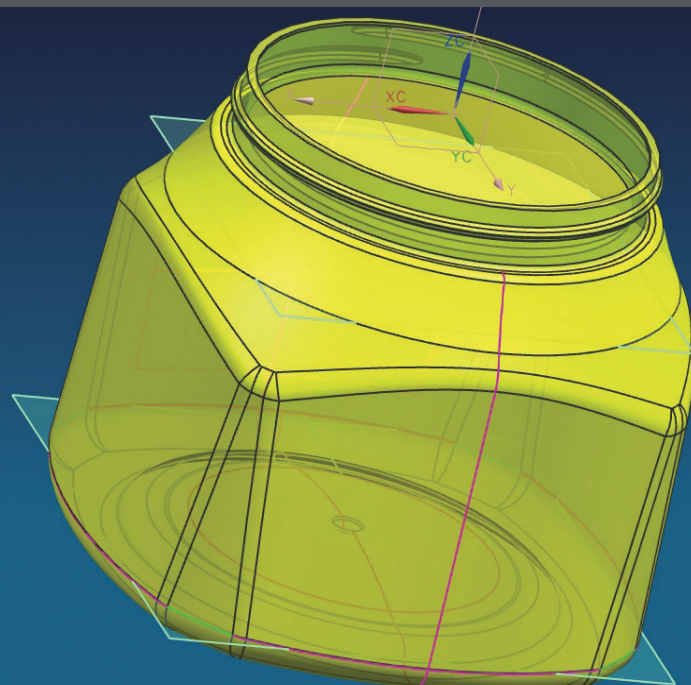

# Sweet Dream

The Silgan Plastics design team evaluated dozens of possible alternatives using sketchpads and design software and finally decided on the 10 best design concepts. In the past, Silgan Plastics would have hired a subcontractor to fabricate plastic models from a thermoformed mold or machine them from a suitable material. The cost for each prototype would have been about \$750 and the leadtime to produce all 10 prototypes would have been roughly one month.

“Our customers want to get their products to market quickly and begin generating revenues,” said Stephen Kocis, Creative Design Services Manager for Silgan Plastics. “We invested in three Stratasys Fused Deposition Modeling (FDM®) machines because FDM prototypes provide the accuracy and detail needed for evaluation by customers of alternative concepts,” Kocis said. “FDM machines are also affordable and can easily be used in an office environment.”

Silgan built FDM prototypes of the 10 design concepts over a 48-hour period at a cost of \$30 in materials and \$270 in FDM machine time and overhead for each. The Truvia team visited the

Silgan Plastics design center where they viewed and handled the prototypes. The team narrowed their selection to a few designs and suggested refinements. “FDM models make it much easier to visualize and evaluate the functionality and ergonomics of a proposed design,” Kocis said.

Silgan Plastics revised the designs and made new FDM prototypes. Tweaking and discussions continued until the Truvia team selected the final package. As the design was finalized for production, Silgan Plastics used the FDM models to check container size and fill levels, evaluate decorating methods, validate distortion in the shrink sleeve graphics and evaluate the moldability of the design.

Consumers and retailers have responded well to the new package. At [fabfindfoodie.com](http://fabfindfoodie.com), one reviewer said: “I love the new Truvia spoonable container. It’s so handy to just pop the top and grab a spoonful of Truvia for my morning coffee or a glass of iced tea in the afternoon. Now instead of having to open a packet every time, all I need is a spoon.” Kocis concluded: “FDM models take the guesswork out of the design process.”



The Truvia package was designed to be attractive enough that consumers would want to display it on their countertop.

Method	Cost (QTY.1)	Lead Time (QTY. 10)
Machine Pattern and Thermoform Prototype	\$2,400	30 Days
FDM Prototype	\$800	2 Days
Savings	\$450 (60%)	28 Days (93%)





### Stratasys Headquarters

7665 Commerce Way,  
Eden Prairie, MN 55344  
+1 800 801 6491 (US Toll Free)  
+1 952 937-3000 (Intl)  
+1 952 937-0070 (Fax)

stratasys.com  
ISO 9001:2008 Certified

1 Holtzman St., Science Park,  
PO Box 2496  
Rehovot 76124, Israel  
+972 74 745 4000  
+972 74 745 5000 (Fax)

©2018 Stratasys Ltd. All rights reserved. Stratasys, Stratasys signet and PolyJet are trademarks or registered trademarks of Stratasys Ltd. and/or its subsidiaries or affiliates and may be registered in certain jurisdictions. All other trademarks belong to their respective owners. Product specifications subject to change without notice. Printed in the USA.  
CS\_FDM\_CN\_SilganPlastics\_0718a

